

26 MARCH 1971 (Supersedes LO5-3810-201-12-3, dtd 9 Feb 1968 and LO5-3810-206-12-3, dtd 18 Mar 1968)

**CRANE-SHOVEL, BASIC UNIT, CRAWLER MOUNTED, 40 TON, 2 CU YD,  
DIESEL DRIVEN, (HARNISCHFEGER MODEL 855 BG, 855 BG-2 AND  
855 BG-3) W/HARNISCHFEGER ENGINE MODEL 687C-18-ES AND  
CATERPILLAR ENGINE MODELS D333TA AND D333C**

Intervals are based on normal hours of operation. Adjust to compensate for abnormal operations and severe conditions. During inactive periods sufficient lubrication must be performed for adequate preservation.

Clean parts with SOLVENT, dry-cleaning, or with OIL, fuel, Diesel. Dry before lubricating.

Lubricate points indicated by dotted arrow shafts on both sides of equipment.

Clean fittings before lubricating.

Relubricate after washing or fording.

LUBRICANT ● INTERVAL

Dragline Dump Sheave GAA 10

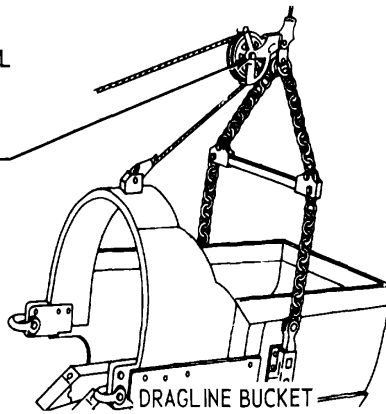

DRAGLINE BUCKET

FOLD

FOLD

INTERVAL ● LUBRICANT

Hoe Stick Sheave Bushings	GAA	10	10	GAA	Hoe Gantry Sheaves (9 fittings)
Hoe Stick Bridle Bushings	GAA	10	10	GAA	Hoe Boom Sheave Pins (2 fittings)
Hoe Stick Pin	GAA	10	10	GAA	Boom Foot Idler Sheaves
Sheave Pin	GAA	10	10	GAA	Boom Foot Sheave
				GAA	Boom Foot Pins
				GAA	Padlock Sheave Pin
				GAA	Boom Point Sheaves
Shipper Shaft Idler Sheave	GAA	10	10	GAA	Bridle Bar Sheave Bushings
Shipper Shaft Bushings	GAA	10	10	CW11	Dipper Handle Racks
Crowd Chain (Clean and Coat)	HDO	10	10	GAA	Saddle Block Bushings
Crowd Chain Idler Sprocket	GAA	10	10	CW11	Dipper Handle Sides and Tops
Crowd Chain Sprocket Bushings	GAA	10	10	GAA	Dipper Trip Lever
Crowd Reverse Gears (Clean and coat)	CW11	10	5	GAA	Padlock Sheave (2 fittings)

BACK HOE

SHOVEL BOOM AND DIPPER STICK

LUBRICANT●INTERVAL

INTER

VAL●LUBRICANT

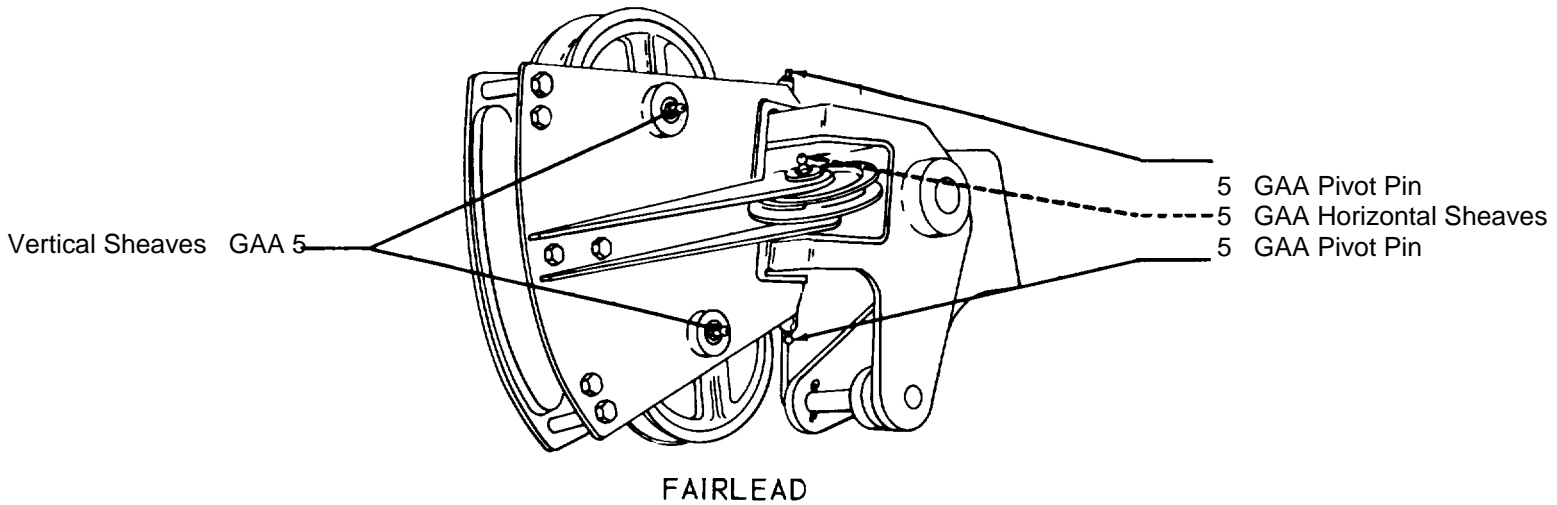
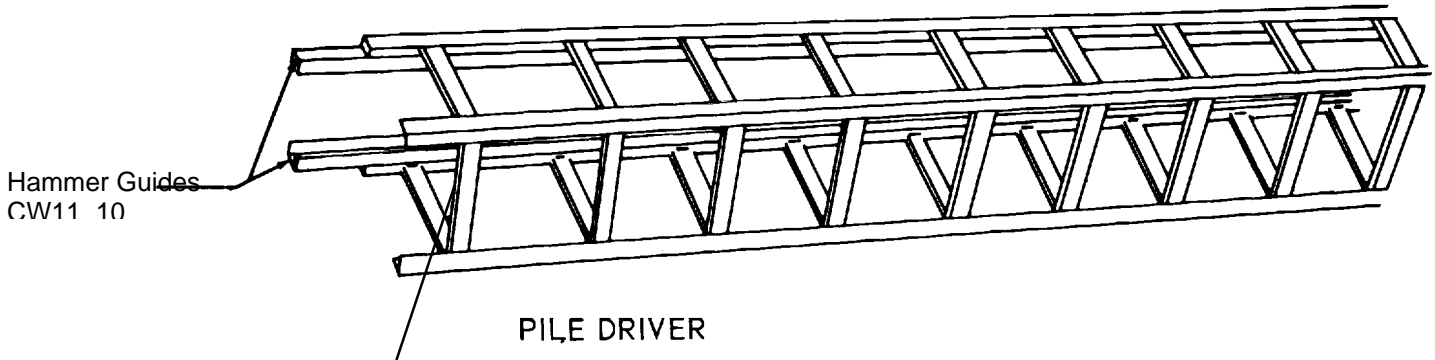

-KEY-

LUBRICANTS	CAPACITY	EXPECTED TEMPERATURES	INTERVALS
HDO-OIL, Engine, Heavy Duty Oil Can Points		Above +32°F	
CW-11B-LUBRICANT, Exposed Gears		+40°F to -10°F	
GAA-GREASE, Automotvie and Artillery		0°F to -65°F	
		HDO 30	Intervals give are in hours of normal operation
		ALL TEMPERATURES	

NOTES

1. FOR OPERATION OF EQUIPMENT IN PROTRACTED COLD TEMPERATURES BELOW -10°F. Remove lubricants prescribed in key for temperatures above -10°F. Relubricate with lubricants specified in the key for temperatures below -10°F.

2. OIL CAN POINTS. Every 10 service hours lubricate all linkage, pins and clevises with HDO.

3. CABLES. Keep cables clean and lubricated with HDO.  
CAUTION: Do not lubricate cables coming in contact with excavated materials.

4. LUBRICANTS. The following is a list of lubricants with the Military Symbols and applicable specification numbers.

HDS MIL-L-45199 GAA MIL-G-10924 CW-11B VV-L-751

Copy of the Lubrication Order will remain with the equipment at all times; instructions contained herein are mandatory.

BY ORDER OF THE SECRETARY OF THE ARMY:

W.C. WESTMORELAND  
General, United States Army  
Chief of Staff

OFFICIAL:

KENNETH G. WICKHAM  
Major General, United States Army  
The Adjutant General

Lo 5-3810-206-12-3 DISTRIBUTION: To be distributed in accordance with DA Form 12-23, Sec II (qty rqr Block #349). Organizational maintenance requirements for Crane Shovels, Crawlers, 40 Ton.



